

# PRODUCT CATALOGUE



**GSN** Electronic Company Ltd.  
[www.gsncompany.com](http://www.gsncompany.com)

# ABOUT US



“GSN Electronic Company Ltd” develops and produces security systems. Our aim is to produce high quality products which are capable of ensuring the most efficient security in a variety of applications, ranging from residential to large scale industrial premises.

During the R&D process we follow up on the demands of the present security system market, taking into consideration the advice of expert installers and comply with international standards, such as ISO 9001: 2008 and RoHS Compliant.

The introduction of unique technical solutions and application of new algorithms, along with extensive laboratory testing, provide our products with a wider scope of functionality.

Notwithstanding the growing volume of general production, our quality control system ensures comprehensive quality supervision along with the adjustment of each product at every stage of the technological process.

The use of up to date assembling equipment, electronic components from the world’s leading manufacturers and the current quality control system, enables us to offer a **5 year** warranty for the entire range of our products.



# TABLE OF CONTENT

## **PASSIVE INFRARED DETECTORS**

PATROL-201PET .....	pp. 8-9
PATROL-401PET.....	pp. 12-13
PATROL-701 .....	pp. 18-19
PATROL-901 .....	pp. 22-23

## **CURTAIN PIR DETECTOR**

PATROL-301 .....	pp. 10-11
------------------	-----------

## **GLASS BREAK DETECTOR**

PATROL-501 .....	pp. 14-15
------------------	-----------

## **CURTAIN PIR & GLASS BREAK DETECTOR**

PATROL-601 .....	pp. 16-17
------------------	-----------

## **PIR & GLASS BREAK DETECTOR**

PATROL-801 ... ..	pp. 20-21
-------------------	-----------

## **UNIVERSAL BRACKET**

UBL-1110 ... ..	pp. 24-25
-----------------	-----------

## **WIRELESS ALARM SETS**

ACS-101 ... ..	pp. 26-27
ACS-102 ... ..	pp. 26-27

## **WIRELESS REMOTE CONTROL SETS**

ACS-112R/114R .....	pp. 28-29
ACS-124R/126R .....	pp. 28-29
ACS-112/124PLUS .....	pp. 30-31
ACS-112R/124R PLUS .....	pp. 30-31

## BIPOLAR DETECTION

The use of microcontrollers in passive infrared detectors enables the application of optimal algorithms to detect a moving person. The **PATROL-401PET** and **PATROL-901** digital PIR detectors apply the latest and most effective method of bipolar detection.

The algorithm, based on bipolar detection, includes an analysis of signals and a calculation of bipolar pulses within certain time intervals and allows the detector to be adapted to various objects with complex operational conditions.

In small premises with a stable climate - such as apartments, small offices or small shops - it is advisable to detect a person by using one monopolar or two bipolar pulses. In large premises with a varying environment, such as industrial plants, malls, supermarkets, warehouses or hangars, where the detector is subject to more severe conditions it is more effective to use a bipolar algorithm, based on 3 or 4 pulses.

The principle of bipolar detection has led to a detector with high interference immunity, which ignores disturbances, such as light exposure, sudden temperature changes, radio frequency interference (RFI) and electromagnetic interference (EMI).

The **PATROL-401** and **PATROL-901** PIR detectors, which are based on bipolar pulse detection, detect successfully a person's movement in spite of the various interferences commonly found in large premises and virtually eliminate false alarms and costly service calls.

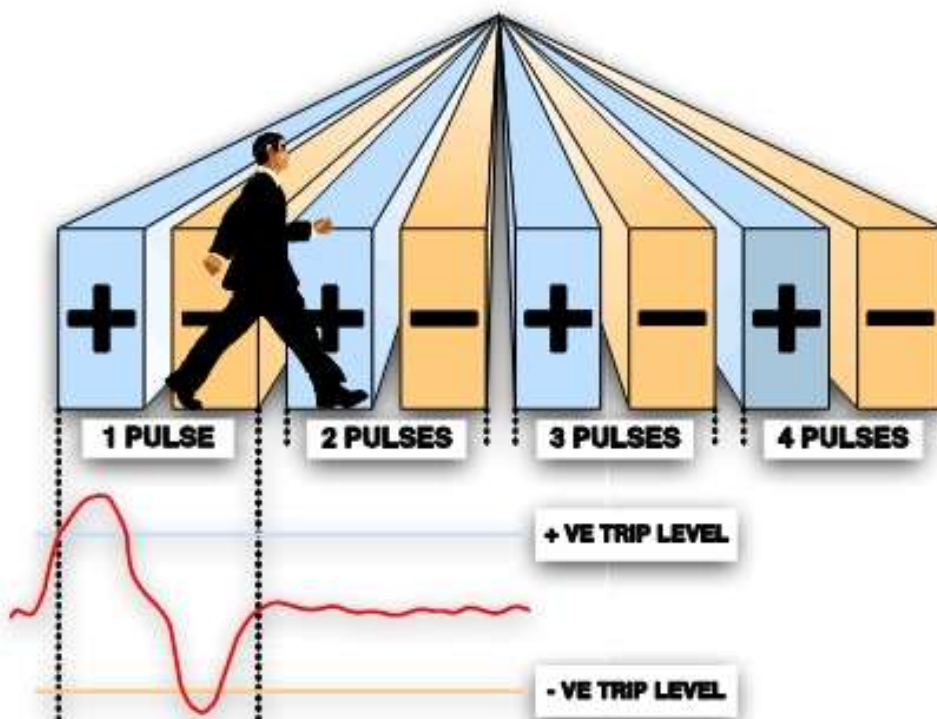

## RADIO FREQUENCY INTERFERENCE RFI IMMUNITY

The **PATROL** series PIR detectors are highly protected against radio-frequency interference.

There is no alarm against a 10 watt transmitter within a range of 1 meter transmitting on a frequency band from 10MHz to 1000MHz.

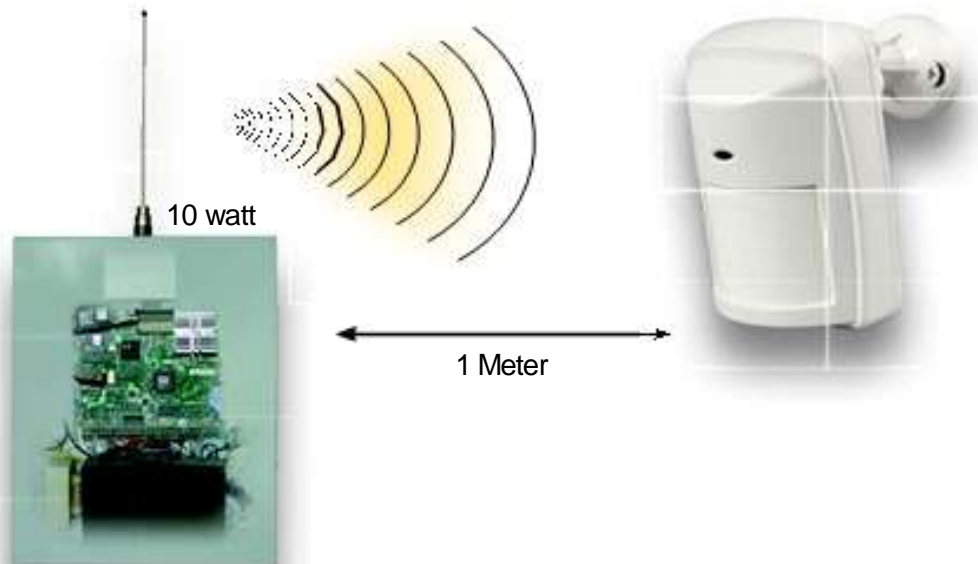

## ELECTROMAGNETIC INTERFERENCE EMI IMMUNITY

One of the reasons for false alarms of detectors is their sensitivity to electromagnetic fields, emitted mainly from power-consumers or various electromagnetic sources. The **PATROL** series PIR detectors apply EMI filters, which protect the detectors from electromagnetic interferences.

EMI filters reduce both differential and general noise levels, thereby excluding false alarms.



## TEMPERATURE COMPENSATION

The **PATROL** series passive infrared detectors are equipped with an automatic temperature compensator, which enables efficient stabilization of the detector's operation, thereby enhancing their immunity to false alarms in harsh environments, particularly with sudden temperature changes.

Automatic Temperature Compensator "Thermistor"



## PYROSENSOR SEALING

Hermetical sealing protects the pyroelectric sensor from penetration of draughts and small insects, thereby eliminating one of the main causes of false alarms.



## OPTOELECTRONIC RELAY

In contrast to conventional electromagnetic relays, the optoelectronic relays OptoMos are more malfunction resistant due to absence of mechanical contact. As a result, the relay's lifespan is significantly lengthened and thus, greater reliability is ensured.

The main advantages of the OptoMos relay are its immunity to external electromagnetic fields and magnets, absence of inductance, constant contact resistance as well as a high speed operation and small power consumption.

Optoelectronic Relay "OptoMos"

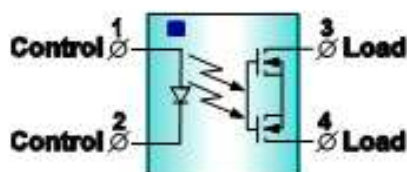
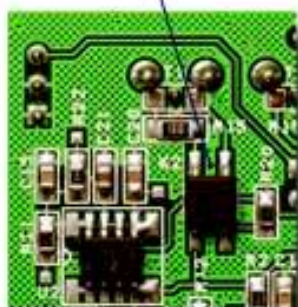

## FRESNEL TECHNOLOGY INC. LENSES

The **PATROL** series passive infrared detectors are equipped with original Fresnel lenses. Fresnel Technologies Inc.'s multifocal optical lenses are made of "POLY IR®" and having the thickness of 0.39mm (0.015") enable the most effective collection of infrared energy from the detected area and exclusion of false alarms resulting from exposure to direct or reflected sunlight or car headlights.

The above lens' properties allow the installation of the **PATROL** series PIR detectors opposite windows.

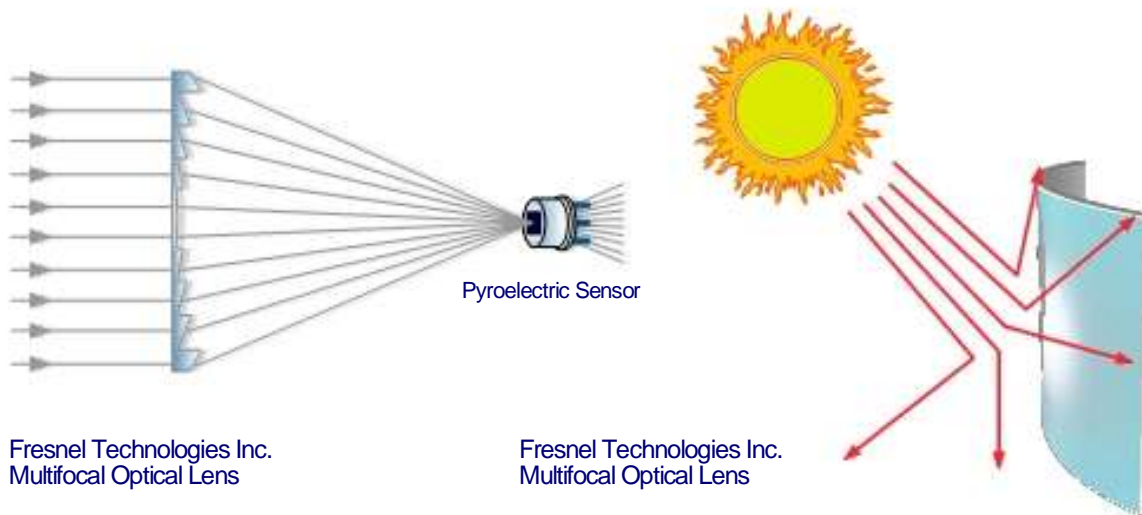

## THE MECHANICAL PROTECTION OF PYROELECTRIC SENSOR

The PIR sensor of the **PATROL-301** and **PATROL-601** detectors is reliably protected from RF interference by special nickel stay.



## PYROELECTRIC SENSORS

Passive infrared detectors equipped with QUAD PIR sensors provide the best protection of a security area.

The **PATROL-401PET** PIR detector with the QUAD PIR sensor provides exact focusing on the detected object, including creep zones. It allows the best possible detection of a moving person in an alarm-protected area.

QUAD ELEMENT PYROELECTRIC INFRARED SENSOR

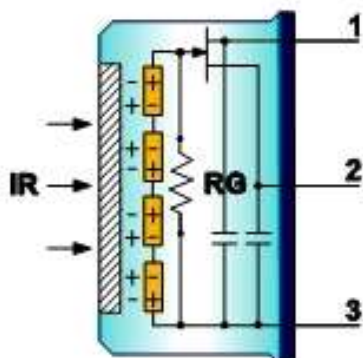

DUAL ELEMENT PYROELECTRIC INFRARED SENSOR

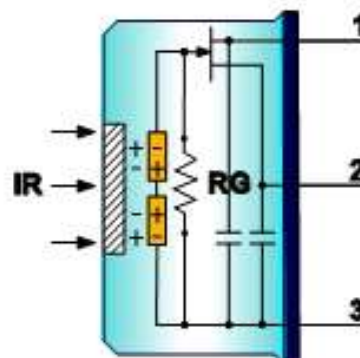

# PATROL- 201PET

## PATROL 201PET HIGH QUALITY PIR DETECTOR.

The **PATROL- 201PET** - is a passive infrared detector, which provides pet immunity up to 20kg.

The **PATROL- 201PET** - incorporates an effective detection system, maximum protection from false alarms and easy and fine PIR sensitivity adjustment to the pet's weight.

The **PATROL- 201PET** - has an elegant design and is suitable for any interior.

## PATROL 201PET ADVANTAGES

- The **PATROL- 201PET** ignores pets of up to 20kg and 1m height.
- Easy and fine PIR sensitivity adjustment to the pet's weight.
- An automatic counter selects and counts incoming pulses in accordance with the strength of incoming signals to the detector.
- An original Fresnel lens protects the detector from false alarms upon exposure to sunlight or headlights.
- A hermetical sealing of the pyroelectric sensor protects the detector from draughts and small insects, thus eliminating one of the main causes of false alarms.
- Coverage range - 15m x 90°.
- Complete protection from radio frequency interference (RFI). There is no alarm against a 10 watt transmitter within 1m at a frequency range of 10MHz to 1000MHz.
- The detector relay is an optoelectronic relay with an unlimited number of operation cycles.
- The detector remains operational at temperatures as low as -30°C.



WIDE ANGLE LENS

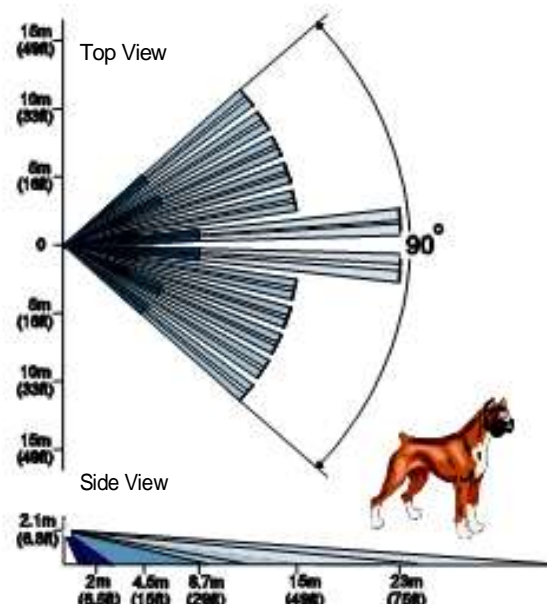



# PATROL- 201PET

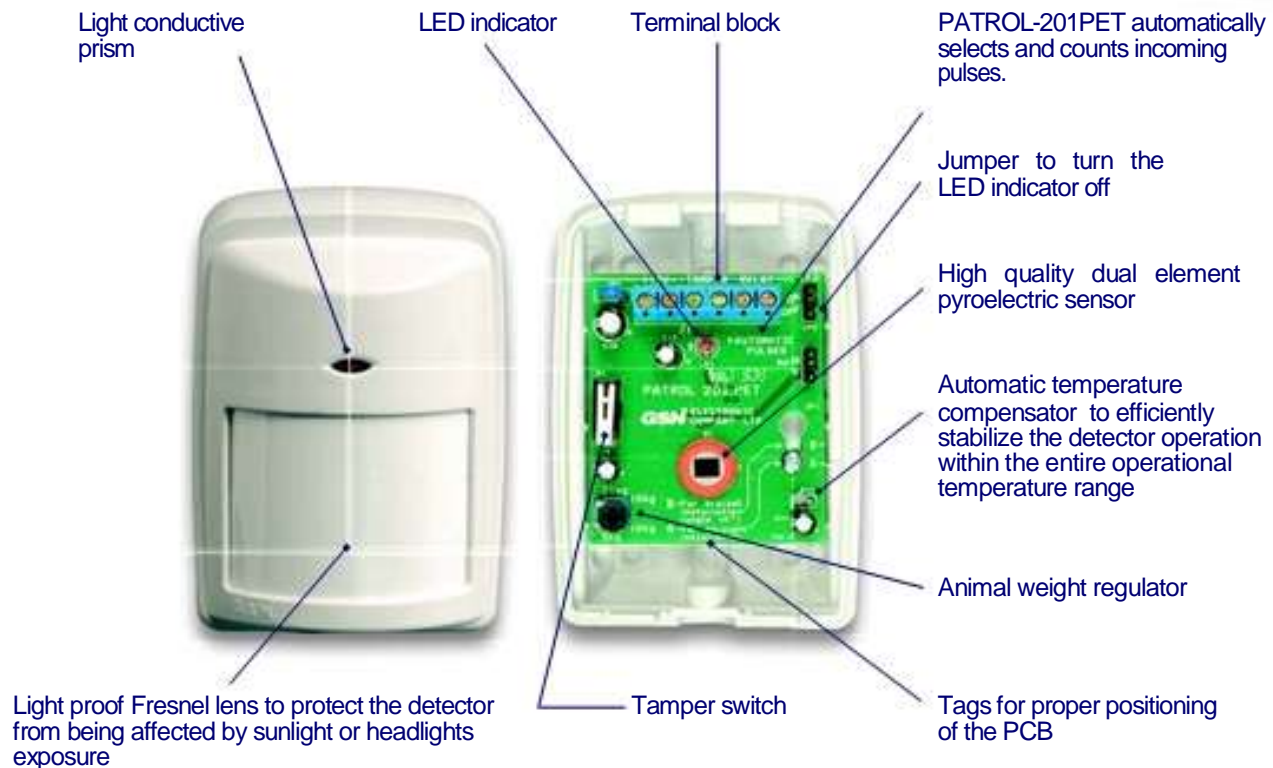

THE PATROL-201PET IS RECOMMENDED FOR BOTH RESIDENTIAL AND INDUSTRIAL PREMISES.

THE PATROL-201PET IS A RELIABLE DETECTOR SERVING IN ACCORDANCE WITH THE NEEDS OF BOTH END USER AND INSTALLER.

## SPECIFICATIONS

Detection speed range: .....0.3-3.0m/sec

Power input: ... .....8.5-16 VDC

Current consumption in alarm mode: .. .....9.7 mA

Pulse mode .....automatic

Alarm period ..... 3 sec

Coverage range: ... .....15m

Relay output: ... .. NC; 60V, 120mA, 16Ω

Light immunity: ... .....not less than 10000 lux

Operating temperature range ... ..-30°C to +50°C

Storage temperature range: .....-40°C to +80°C

RFI immunity: .....30V/m at a frequency range ... .....10MHz-1000MHz

EMI immunity .....>0.5kV

Weight ..... 94gr.

# PATROL-301

## DIGITAL CURTAIN PIR DETECTOR PROVIDES UNBEATABLE WINDOWS, ALL GLASS WALLS, DOORS AND OTHER OPENINGS PROTECTION.

The **PATROL-301** creates solid curtain coverage of up to 15m length x 10m height and enables extremely accurate detection of humans in the protected area.

The **PATROL-301** ensures the unrivalled level of windows, all-glass walls, doors and other openings protection in the detection zone and provides the security systems with stable "false alarm free" operation.

The **PATROL-301** is the most elegant curtain-type PIR detector at the modern security market.

### PATROL 301 ADVANTAGES

- The **PATROL-301** is equipped with the original Fresnel lens, which most effectively collects IR energy from the detected area and focuses it directly onto the pyro sensor. By using special "POLY IR" lens material that reduces the negative effects of visible light, the **PATROL-301** eliminates false alarms caused by exposure to direct or reflected sunlight or car headlights.
- The **PATROL-301**, equipped with the QUAD PIR sensor, creates high density detection zone, eliminating undetectable area, and allows the best possible detection of a moving person in an alarm protected object.
- The **PATROL-301** sensitivity regulator allows the detector to be adapted to various objects with certain operational conditions.
- Double RFI and EMI protection:  
The reliable electronic circuit protection by RF and EM filters.  
The mechanical protection of pyroelectric sensor. The PIR sensor of the **PATROL-301** is protected from RF interference by nickel stay.
- The bipolar pulse counter, which is under the microprocessor control, ensures the stable **PATROL-301** operation at the objects with unstable and harsh environment.
- The detector relay is an optoelectronic relay with an unlimited number of operation cycles.
- **PATROL-301** is 100% factory-tested for reliability.
- **PATROL-301** has an attractive and up-to-date design to blend into any décor.

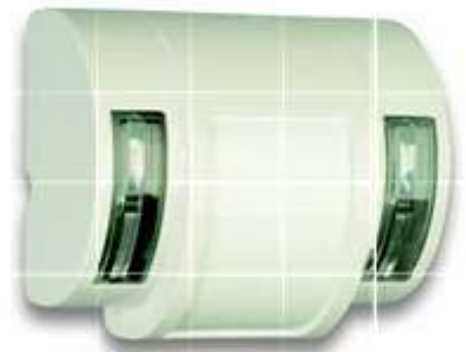

THE PATROL-301 IS THE STYLISH AND RELIABLE DETECTOR TO PROVIDE THE PROFESSIONAL WINDOWS, ALL-GLASS WALLS, DOORS AND OTHER OPENINGS PROTECTION.

# PATROL-301

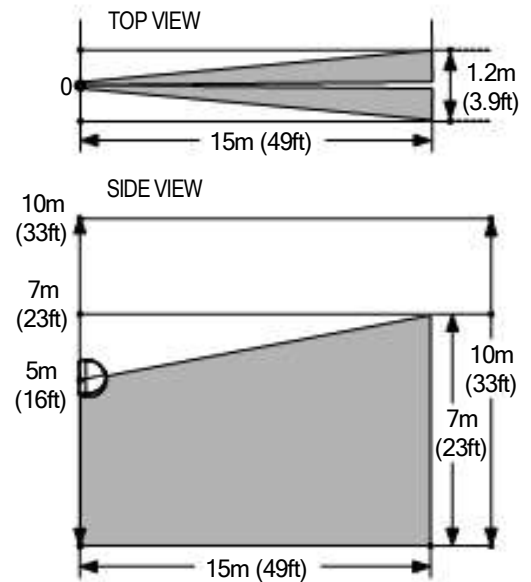
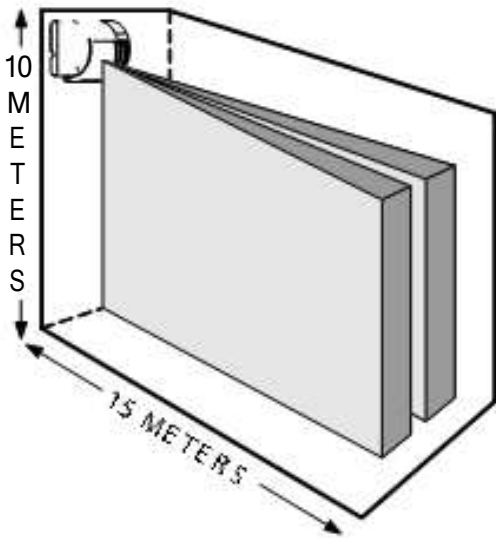
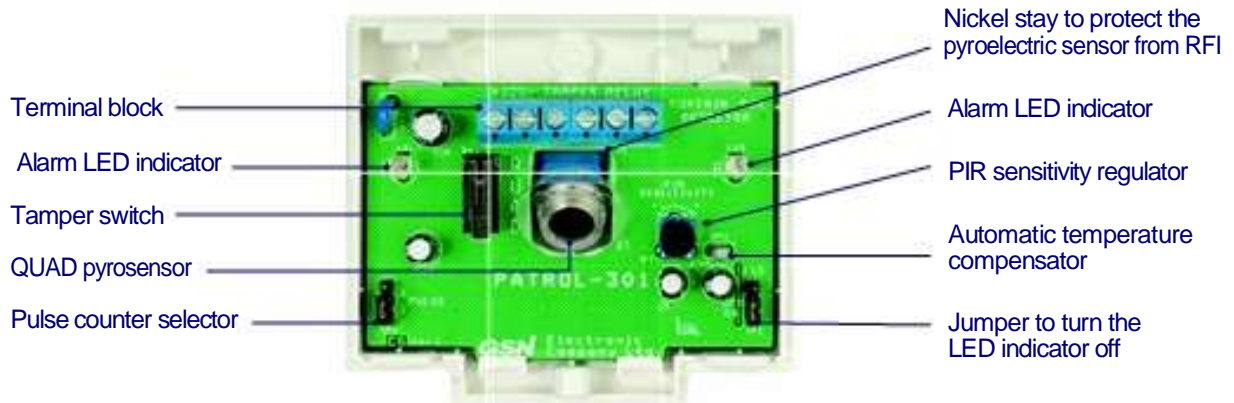

## SPECIFICATIONS

Detection speed range .....	0.2-3.0 m/sec
Power input .....	8.5-16 VDC
Current consumption	
in stand-by mode .....	12.2mA
In alarm mode with LED on .....	13.2mA
Pulse mode .....	1,2
Alarm period .....	3 sec
Warm up period .....	40 ± 1 sec
Relay output .....	NC; 60V, 120mA, 17Ω

Detection range .....	15m
Installation height .....	up to 10m
Light immunity .....	not less than 10000 lux
Operating temperature range .....	- 30°C to + 50°C
Storage temperature range .....	- 50°C to + 80°C
RFI immunity .....	30 V/m
at a frequency range .....	10MHz-1000MHz
EMI immunity .....	>0.5kV
Weight .....	106gr.

# PATROL-401PET

## STATE OF THE ART TECHNOLOGY & RELIABILITY.

The **PATROL-401PET** is a digital passive infrared detector, immune to pets up to 35kg. A combination of a unique, cutting-edge technology of bipolar detection and the QUAD PIR pyroelectric sensor makes the **PATROL-401PET** the most stable detector, flawlessly immune to pets up to 35kg and capable of providing reliable detection in harsh environments.

## PATROL 401PET FEATURES

- The **PATROL-401PET** is immune to pets of up to 35 kg and 1 m height.
- The **PATROL-401PET**, equipped with QUAD sensor, forms numerous segments of detection zones and enables exact focusing of IR energy from any detected area.

QUAD ELEMENT PYROELECTRIC INFRARED SENSOR

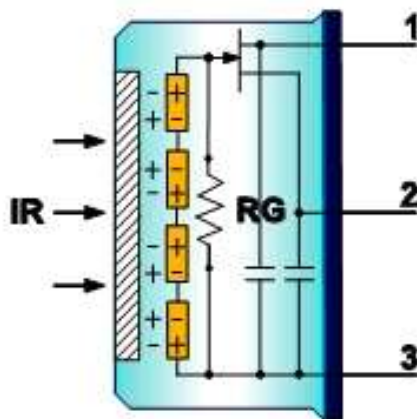

WIDE ANGLE LENS

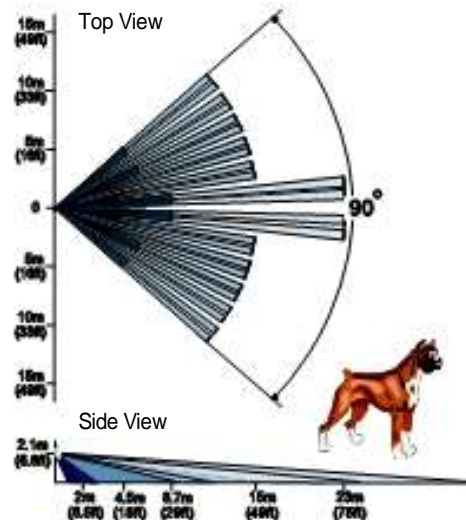

## A UNIQUE ALGORITHM

The operating principle of the **PATROL-401PET** algorithm is based on a bipolar pulse counter and is under microprocessor control to flawlessly detect human motion in a secured area, completely eliminating false alarms and ensuring the stable operation of the detector in harsh environments.

BIPOLAR PULSE COUNTER

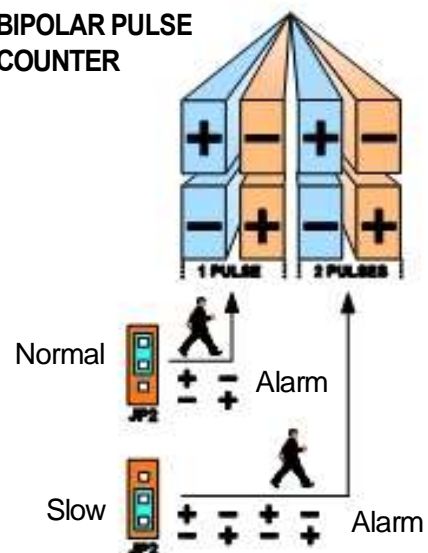

# PATROL-401PET

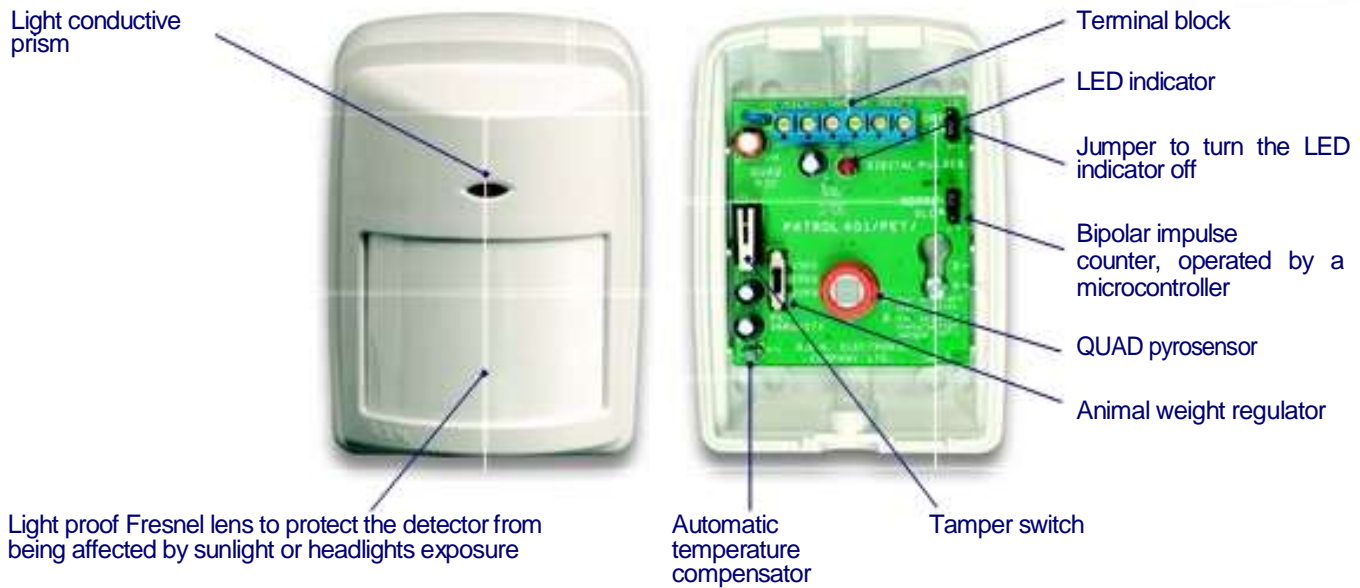

- **PATROL-401PET** - has complete protection from radio frequency interference (RFI). There is no alarm against a 10 watt transmitter within 1m range at a frequency of 10MHz to 1000MHz.
- Hermetical sealing of the pyroelectric sensor protects the detector from draughts and small insects, thus eliminating one of the main causes of false alarms.
- The detector remains operational at temperatures as low as -30°C.

THE PATROL-401PET IS THE IDEAL DETECTOR FOR PROVIDING SECURITY IN LARGE COMMERCIAL AND INDUSTRIAL AREAS.

THE PATROL-401PET ENSURES STABLE OPERATION AND RELIABLE SECURITY IN HARSH INDUSTRIAL ENVIRONMENTS.

## SPECIFICATIONS

Detection speed range: ..... 0.3-3.0m/sec  
 Power input: .....8.5-16 VDC  
 Current consumption in alarm mode: .. ...11.5 mA  
 Pulse mode: ..... bipolar 1,2  
 Alarm period: ..... 3 sec  
 Detection range: ..... .15m  
 Relay output: ... ..... NC; 60V, 120mA, 16Ω

Light immunity : .....not less than 10000 lux  
 Operating temperature range ... ..-30°C to +50°C  
 Storage temperature range: ..... -40°C to +80°C  
 RFI immunity: .....30V/m  
 at a frequency range: ... .....10MHz-1000MHz  
 EMI immunity: .....>0.5kV  
 Weight: .....95gr.

# PATROL-501

## DIGITAL ACOUSTIC GLASS BREAK DETECTOR THE LEADER OF NEW TECHNOLOGIES OF FLAWLESS PROTECTION OF ALL KNOWN GLASS TYPES.

### PATROL 501 FEATURES

- Highly selective sensitivity
- Dual-channel detection of the break (impact) / sound signals sequence
- Digital mathematical algorithm of signal processing
- Extraordinary immunity to false alarms
- Stable operation in harsh environments
- Ideal protection from RF and EM interferences
- Automatic microphone overload protection
- Last event memory time: 30min
- Protects all glass types
- Elegantly designed to blend into any decor

### ALGORITHM

Unique algorithm is based on recognition of sequence of low-frequency and high-frequency signals of framed pane glass breakage.



#### HIGH-FREQUENCY SIGNAL    LOW-FREQUENCY SIGNAL

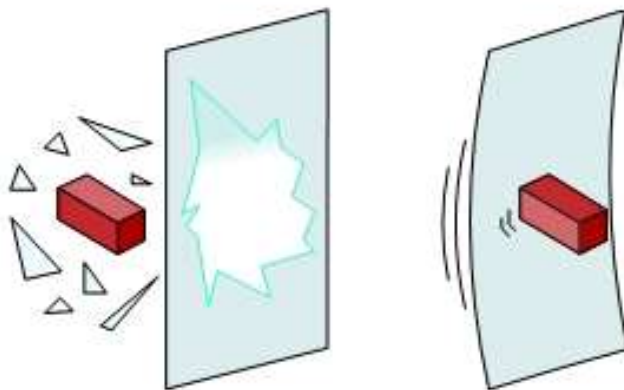

Low-frequency signal is emitted upon the impact of glass.  
High-frequency signal occurs upon the glass breakage.

For creating an alarm, both a low-frequency sound of the glass impact and a high-frequency glass breakage sound must be registered within a predetermined time frame.

Since both detector channels must register the actual glass breakage, false alarms are practically excluded.

The program of microcontroller, based on the mathematical algorithm, analyzes signals and detects only the actual breakage of all standard framed glass types.

## RELIABILITY

Due to the unique program and perfectly adjusted filters the **PATROL-501** provides excellent protection from false alarms in extremely harsh environments. Highly selective sensitivity of the high frequency channel enables the **PATROL-501** to detect real glass breakage with high accuracy among a variety of background noises. The above features enable the **PATROL-501** to be used in extremely harsh environments, such as airports, industrial plants as well as in the vicinity of noisy restaurants, bars, etc. High RFI and EMI immunity allows the detector to be mounted next to radio and electromagnetic emission sources.

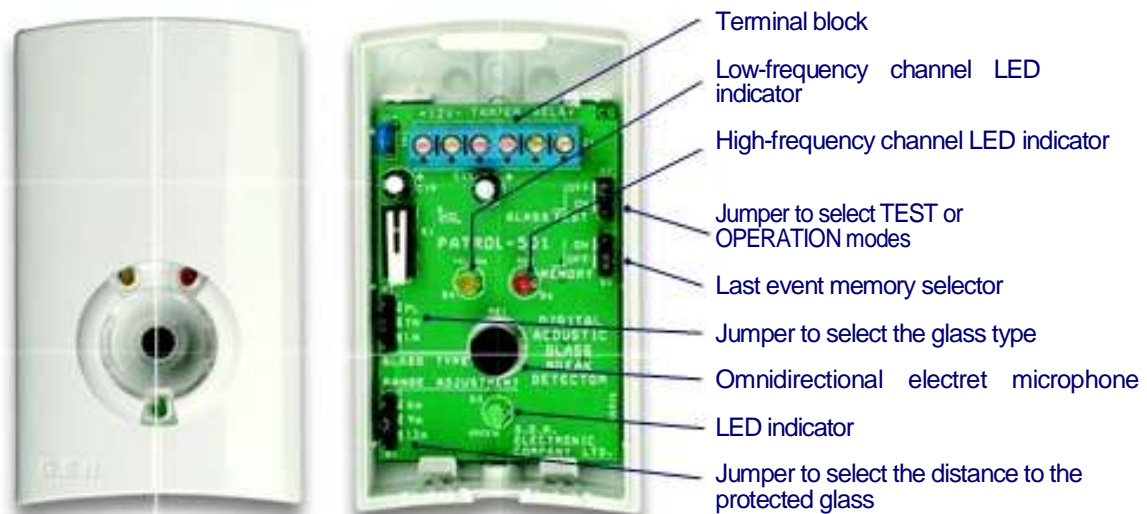

THE PATROL-501: PROFESSIONAL AND RELIABLE.

THE PATROL-501: THE BEST SOLUTION TO GLASS PROTECTION IN A SECURITY AREA.

## SPECIFICATIONS

Power input: ... .. 9-16 VDC	Last event memory: .....30min
Current consumption in standby mode: ... 17.8mA	Operating temperature range ... ..-30°C to +50°C
Current consumption in alarm mode: ... .. 18.7mA	Storage temperature range: ... ..-40°C to +80°C
Alarm period: ..... 3 sec	RFI immunity: .....30V/m
Warm up period: .....2 sec	at a frequency range: ..... .10MHz-1000MHz
Detection range: ..... 12m X 170°	EMI immunity: .....>0.5kV
Relay output: ... ..NC; 60V, 120mA, 16Ω	Dimensions: .....87mm x 52mm x24mm
Tamper: ..... NC; 10Ω	Weight: ..... 58gr.
Microphone type: ... .....omnidirectional electret microphone	

# PATROL-601

## DIGITAL COMBINED CURTAIN PIR & GLASS BREAK DETECTOR IS A BREAKTHROUGH IN PROFESSIONAL WINDOWS, ALL GLASS WALLS, GLASS DOORS AND SKYLIGHTS PROTECTION.

The **PATROL-601** is a combination of 2 detectors in one.

The **PATROL-601** incorporates two cutting edge intrusion detection technologies by PIR detector and glass break detector.

The **PATROL-601** has two microphones for the frequency separation of sound signals: Shock /Glass breakage.

### PATROL 601 ADVANTAGES

- **QUAD PIR SENSOR**

The **PATROL-601**, equipped with QUAD PIR sensor, eliminates undetectable zones and ensures the best detection of the infrared energy radiating from the moving intruder in an alarm protected area.

- **EXCEPTIONAL DIRECT AND REFLECTED LIGHT PROTECTION**

The **PATROL-601** is equipped with the original Fresnel lens made of "POLY IR", which enables the best penetration of infrared energy and exclusion of false alarms resulting from exposure to direct or reflected sunlight or car headlights.

- **TWO MICROPHONES FOR FREQUENCY SEPARATION OF ACOUSTIC SIGNALS: SHOCK / GLASS BREAKAGE**

The usage of two microphones in the **PATROL-601** allowed to separate high-frequency and low-frequency components of the acoustic signal, thus significantly to increase the selective sensitivity of the acoustic detector, to enlarge the detection range and to detect the real glass breakage only.

- **TWO TEST MODES GLASS TEST AND SHOCK & GLASS TEST**

There are 2 test modes for the glass break detector testing:

Test and adjustment of the high frequency channel - "GLASS TEST".

Complete test of the glass break detector - "SHOCK & GLASS TEST".

- **TWO SENSITIVITY REGULATORS**

The **PATROL-601** sensitivity regulators adjust the PIR detector and the glass break detector sensitivity according to the certain surround conditions, thus increasing the **PATROL-601** resistance to all kinds of environmental disturbances.

- **TWO OPTOELECTRONIC RELAYS**

Two independent optoelectronic relays of the PIR detector and the glass break detector allow connecting the **PATROL-601** to two independent zones in the control panel.

- **DOUBLE RFI / EMI PROTECTION**

The reliable electronic circuit protection by RF and EM filters.

The mechanical protection of pyroelectric sensor. The PIR sensor of the **PATROL-601** is protected from RF interference by special nickel stay.

- **BIPOLAR PULSE COUNTER**

The algorithm, based on bipolar pulse counting, allows the detector to be adapted to various objects with complex operational conditions, such as industrial plants, supermarkets, storehouses and hangars.





# PATROL-601

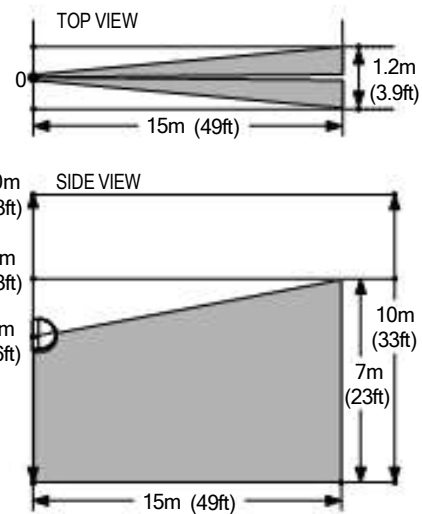
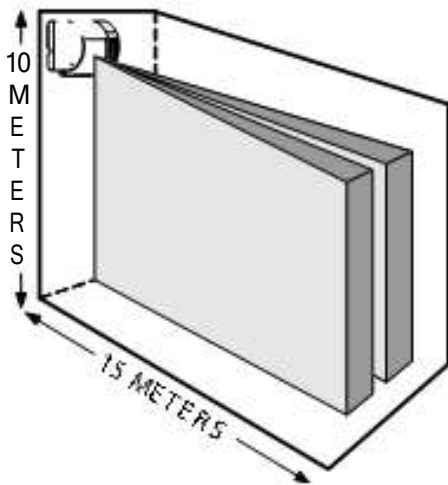
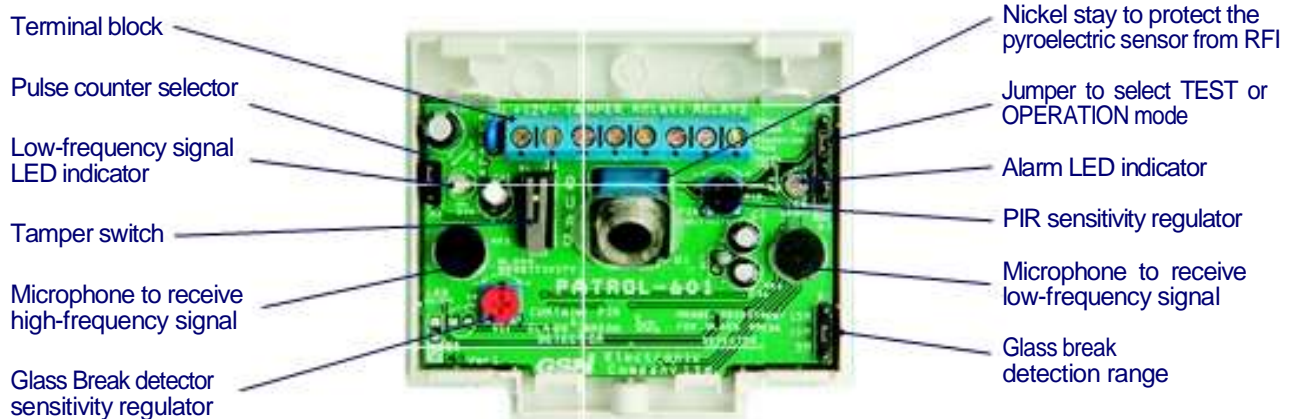

THE PATROL-601 - UNPRECEDENTED DOUBLE PROTECTION AND STYLISH DESIGN - IS A CHOICE OF PROFESSIONALS.

## SPECIFICATIONS

Detection speed range .....	0.2-3.0 m/sec	PIR detection range .....	15m
Power input .....	8.5-16 VDC	Glass break detection range .....	15m x 180°
Current consumption in stand-by mode .....	20mA	Installation height .....	up to 10m
In alarm mode with LED on ...	21mA	Operating temperature range .....	- 30°C to + 50°C
Pulse mode .....	1,2	Storage temperature range ...	- 50°C to + 80°C
Alarm period .....	3 sec	RFI immunity .....	30 V/m
Warm up period ...	.50 ± 2 sec	at a frequency range .....	10MHz-1000MHz
Relay output ...	.NC; 60V, 120mA, 17Ω	EMI immunity .....	>0.5kV
Light immunity .....	not less than 10000 lux	Weight .....	106gr.

# PATROL-701

## PASSIVE INFRARED DETECTOR: AN EXAMPLE OF RELIABLE DETECTION.

The **PATROL-701** incorporates an efficient detection system, maximum protection from false alarms and a modern, elegant design.

The **PATROL-701** is an ideal infrared human motion detector, evenly covering every point of the detection area.

## THE PATROL 701'S ADVANTAGES

- Automatic selection and counting of incoming pulses in accordance with the strength of input signals.
- A sensitivity regulator to reliably stabilize the detector's operation.
- An optoelectronic switch relay with an unlimited number of operation cycles.
- Covered area: 18 m x 90°



### WIDE ANGLE LENS

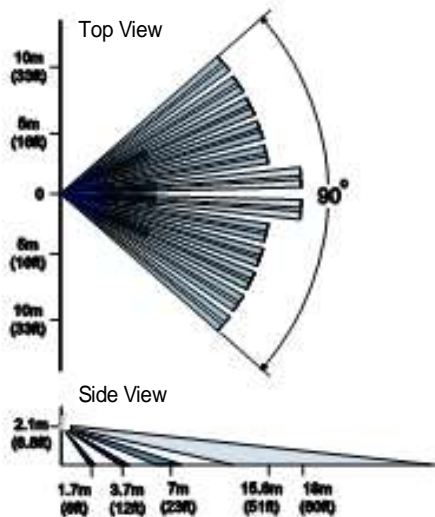

### LONG RANGE LENS

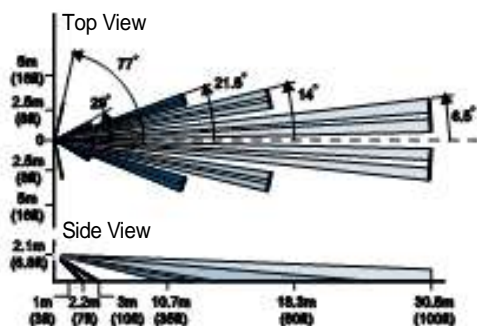

### VERTICAL CURTAIN LENS

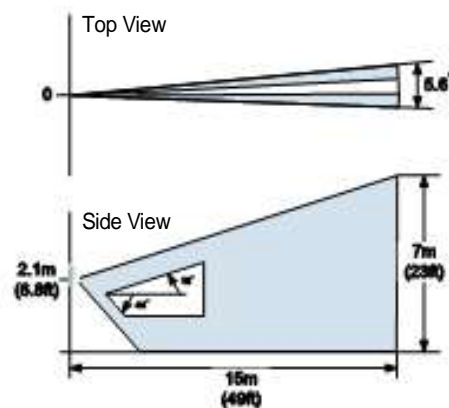

# PATROL-701

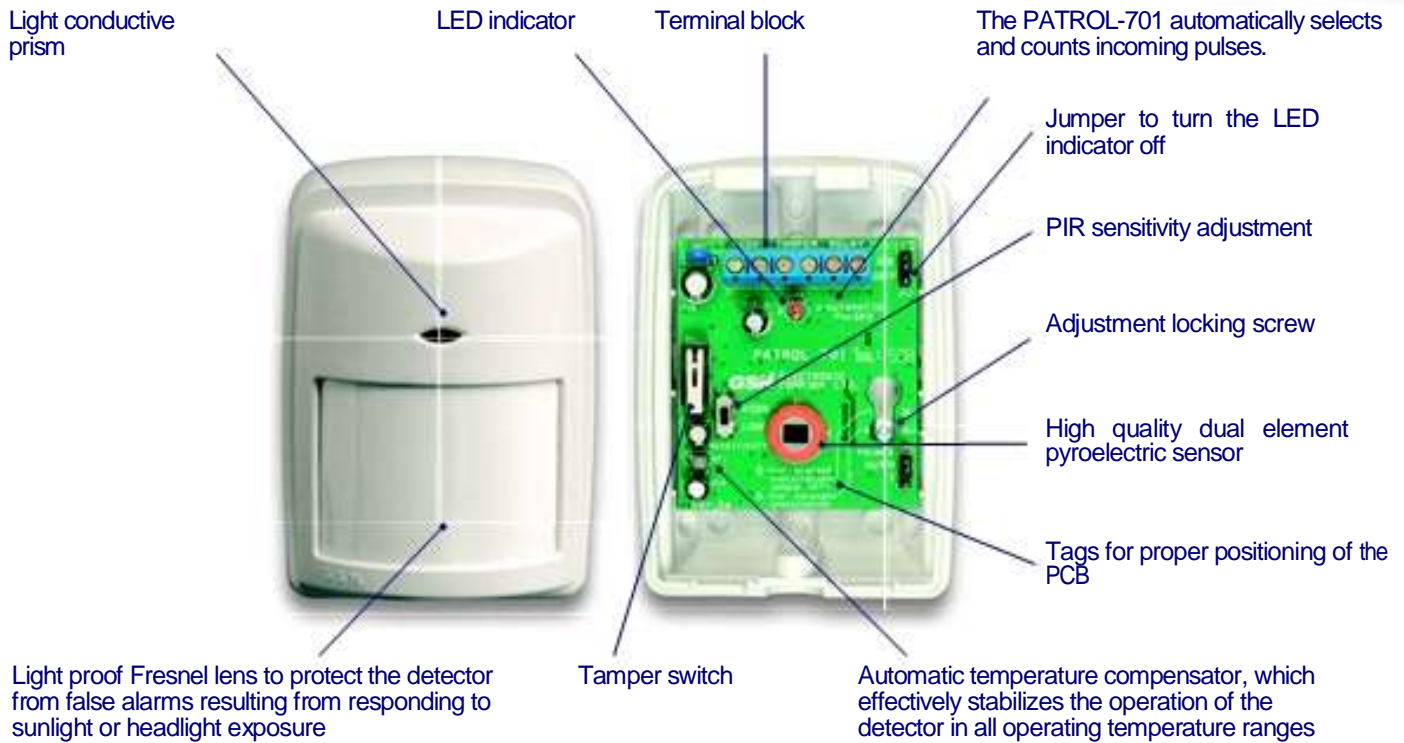

- Guaranteed RFI protection. There is no alarm against a 10 watt transmitter within 1m at a frequency range of 10MHz to 1000MHz.
- Hermetical sealing of the pyroelectric sensor protects the detector from draughts and small insects, thus eliminating one of the main causes of false alarms.
- The detector remains operational at temperatures as low as -30°C.

THE PATROL-701 ENABLES THE BEST PROTECTION AT THE LOWEST COST.

THE PATROL-701 IS THE PERFECT DETECTOR  
TO MEET YOUR HIGHEST EXPECTATIONS AND DEMANDS.

## SPECIFICATIONS

Detection speed range: ..... 0.3-3.0m/sec  
 Power input: .....8.5-16 VDC  
 Current consumption in alarm mode: ..... 10 mA  
 Pulse mode: ..... automatic  
 Alarm period: .....3 sec  
 Detection range: ..... 18m  
 Relay output: ..... NC; 60V, 120mA, 16Ω

Light immunity: .....not less than 10000 lux  
 Operating temperature range ... ..-30°C to +50°C  
 Storage temperature range: .....-40°C to +80°C  
 RFI immunity: .....30V/m  
 at a frequency range: ..... 10MHz-1000MHz  
 EMI immunity: ..... >0.5kV  
 Weight: .....94gr.

# PATROL-801

## COMBINED DIGITAL PIR & GLASS BREAK DETECTOR. CUTTING EDGE TECHNOLOGY AND EXCEPTIONAL RELIABILITY.

The **PATROL-801** is a combination of PIR and acoustic glass break detectors. The PIR detector analyzes the environment and detects the person's motion crossing the infrared beam. The acoustic glass break detector identifies the sounds of glass impact and breakage.

The **PATROL-801** incorporates two cutting edge detection technologies.

The **PATROL-801** enables an exceptionally reliable detection and stable "false alarms free" operation in unstable environments.

### • RELIABILITY

The unique program for processing incoming signals from PIR and GLASS BREAK detectors employs a mathematical algorithm and provides the **PATROL-801** with the important advantages of flawlessly detecting, processing and making decisions on starting an alarm, even in extremely harsh environments. At the same time it filters noise, light, electromagnetic and other interferences, thus making the PATROL-801 the most reliable and stable, top quality device.

### • EXTREMELY NOISY ENVIRONMENTS

The highly selective sensitivity of the high-frequency acoustic channel enables the device to detect a breakage of any known type of glass and reveal an actual breakage in a background of various noise interferences.

This feature enables the installation of the **PATROL-801** in a variety of noisy premises, such as airports and industrial plants as well as in the vicinity of noisy restaurants, bars, etc.

### • RFI PROTECTION

The **PATROL-801** has exceptional protection against RF interference, which enables the detector to operate in close proximity to radio transmitters. There is no alarm against a 10 watt transmitter within 1m at a frequency range of 10MHz to 1000MHz.

### • DESIGN AND OPTIC SEALING

The housing is designed for convenient installation and maintenance. To install the detector on the wall, a universal bracket is used. A bracket is illustrated on page 20. To place the detector onto bracket, knockouts are provided at the back of the housing.

A hermetical sealing of the pyroelectric sensor protects the detector from draughts and small insects, thus eliminating one of the main causes of false alarms.

### • FRESNEL LENS

A multifocal optical lens with a denser occupancy of the detection zones and a wide 110° angle of view enables high detection accuracy, simultaneously protecting the detector from false alarms, resulting from exposure to sunlight and headlights.

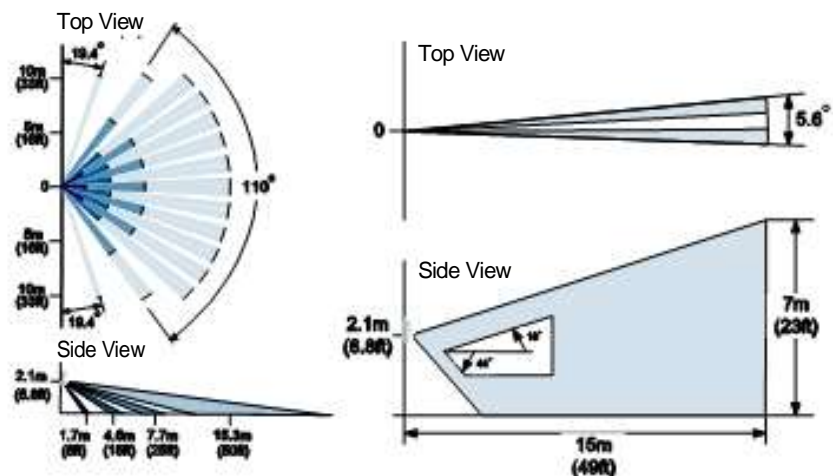

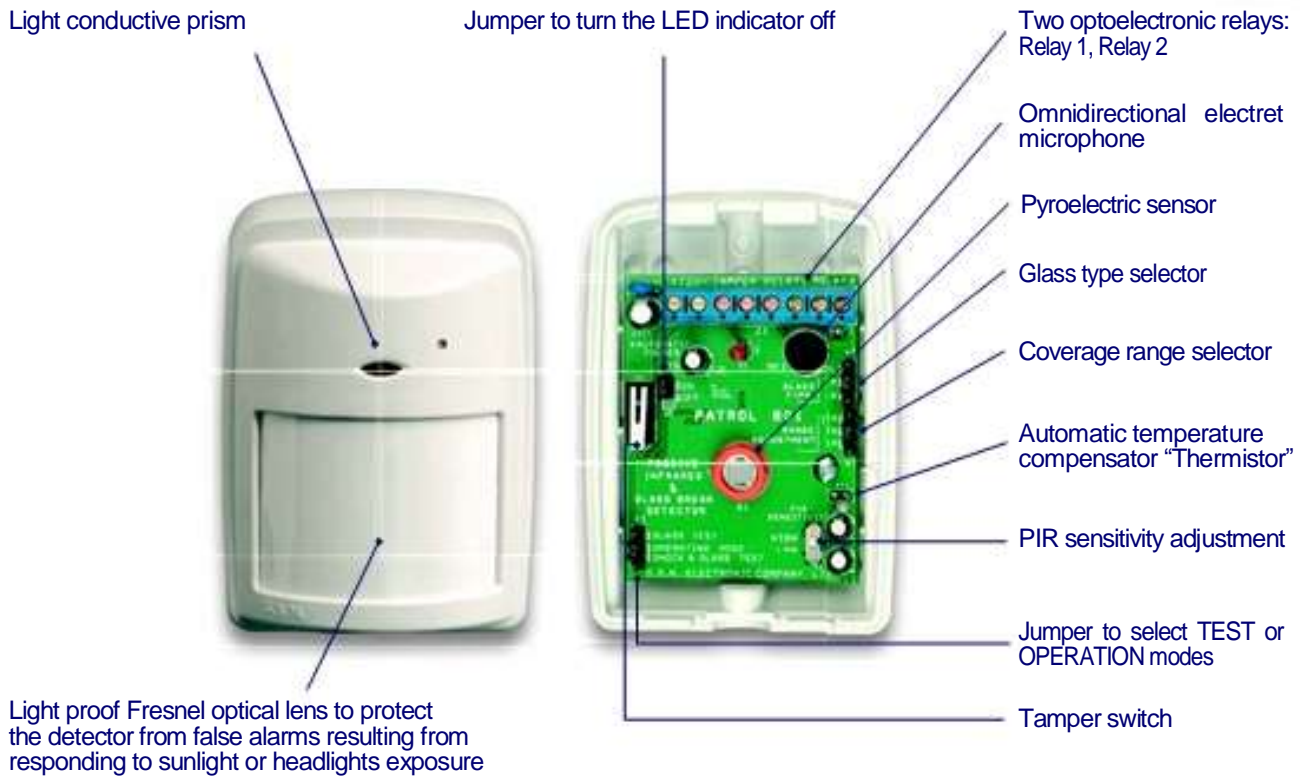

THE PATROL-801 IS THE IDEAL DETECTOR TO BE USED IN A WIDE RANGE OF COMMERCIAL AND INDUSTRIAL INSTALLATIONS UNDER EXTREMELY HARSH CONDITIONS.

## SPECIFICATIONS

Detection speed range: .....	0.3-3.0m/sec	Relay output: .....	NC; 60V, 120mA, 16Ω
Power input: ... ..	8.5-16 VDC	Light immunity: .....	not less than 10000 lux
Current consumption in standby mode: ..	18.4 mA	Operating temperature range ... ..	-30°C to +50°C
Current consumption in alarm mode: ... ..	19.1mA	Storage temperature range: .....	-40°C to +80°C
Pulse mode: ... ..	automatic	RFI immunity: .....	30V/m
Alarm period: ... ..	3 sec	at a frequency range: .....	10MHz-1000MHz
Warm up period: ... ..	40 ± 2 sec	EMI immunity: .....	>0.5kV
Detection range: .....	15m x 110°	Weight: .....	97gr.
Glass break detection range: .....	12m x 160°		

# PATROL-901

## DIGITAL TECHNOLOGY ENHANCES RELIABILITY FOR EXTREMELY HARSH ENVIRONMENTS.

**PATROL-901** - a perfect digital detector, aimed at those who demand high level security.

**PATROL-901** - applies the latest and most effective method of bipolar detection. The algorithm, based on bipolar detection, includes an analysis of signals and a calculation of bipolar pulses within certain time intervals and allows the detector to be adapted to various objects with complex operational conditions.

**PATROL-901** - provides the most reliable and stable operation in premises with extremely harsh environments, where the use of analog detectors is not reliable.

### BIPOLAR PULSE COUNTER

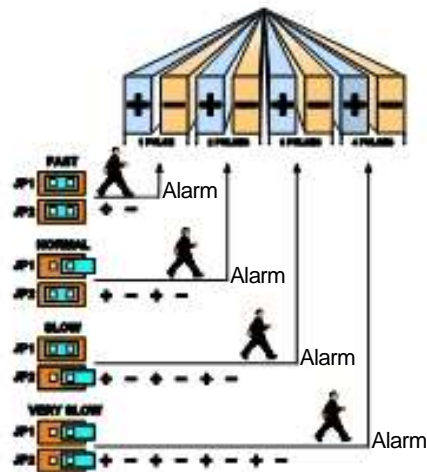

- The combination of multifocal optical lens and bipolar detection algorithm creates the **PATROL-901** free of false alarms. The **PATROL-901** has high immunity against sunlight and headlights and can be installed opposite windows.

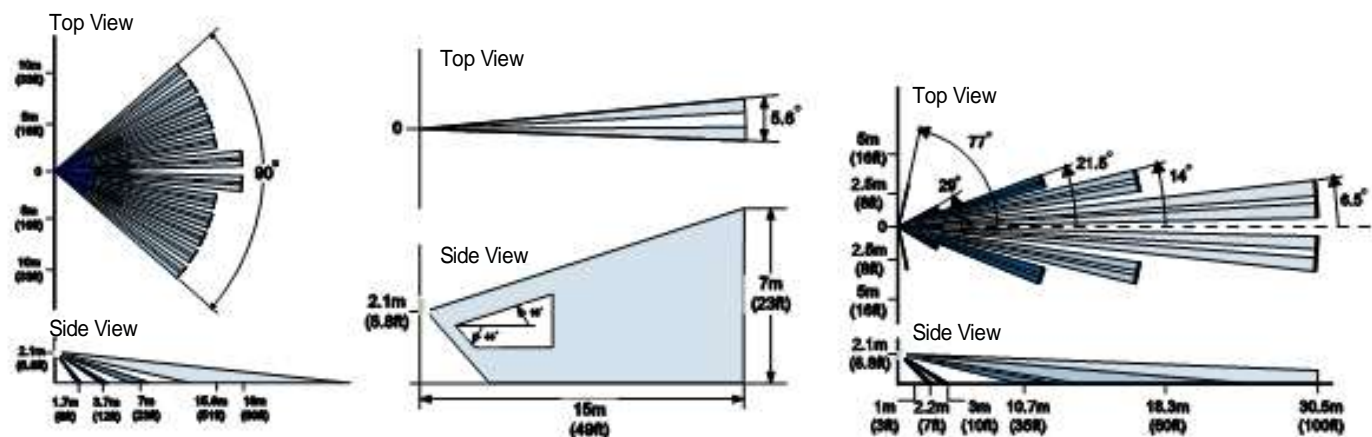

- Hermetical sealing of the pyroelectric sensor protects the detector from draughts and small insects, thus eliminating one of the main causes of false alarms.
- Self diagnostics - the microcontroller controls the detector's basic circuit.
- High RFI and EMI immunity allows the detector to be mounted next to sources of radio and electromagnetic emission. **PATROL-901** detector does not respond to a 10 watt transmitter within a range of 1m transmitting on a frequency band from 10MHz to 1000MHz.
- The detector remains operational at temperatures as low as -30°C.

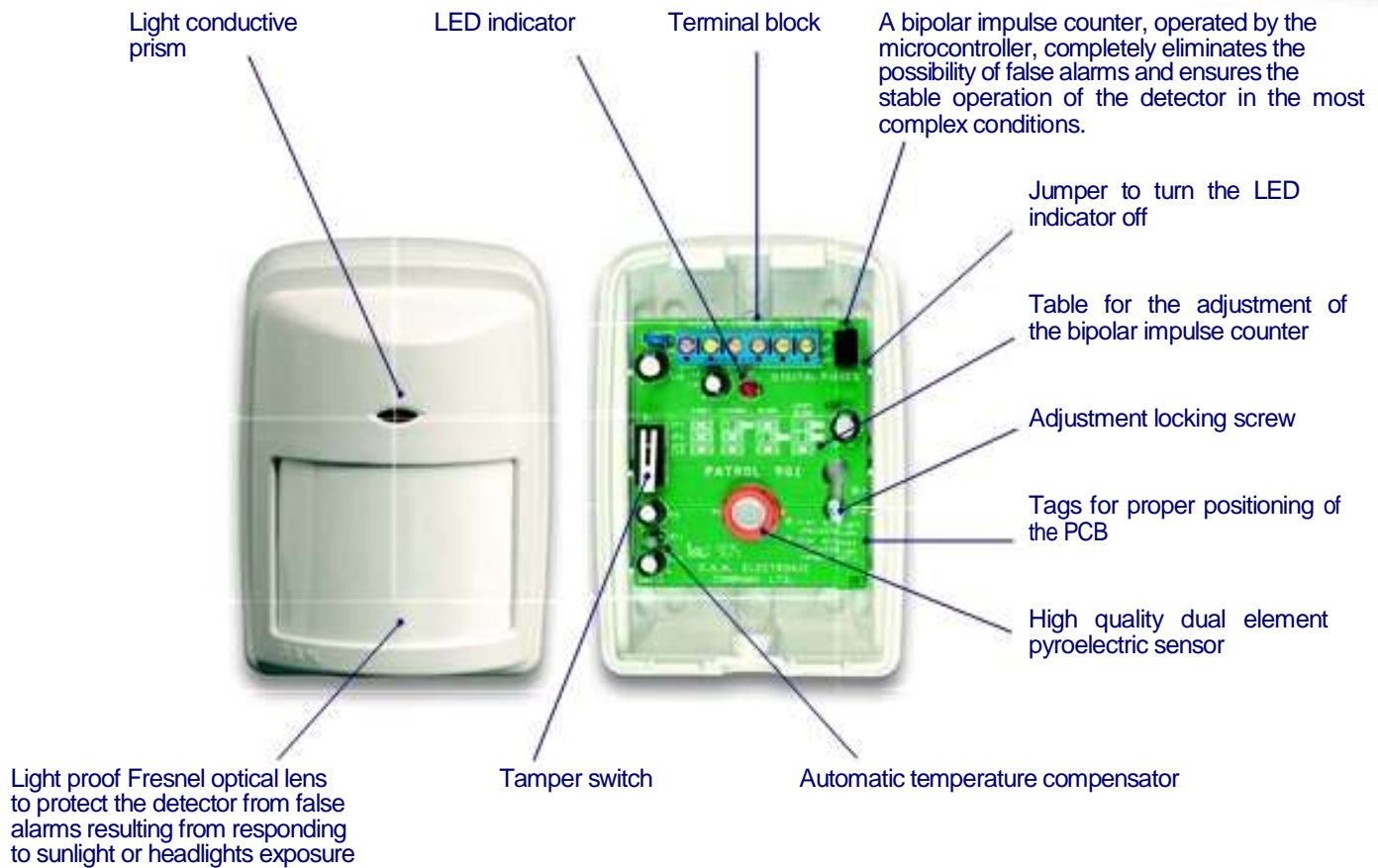

THE PATROL-901 IS THE IDEAL SOLUTION TO THE CONSTRUCTION OF A SECURITY SYSTEM IN COMPLEX SURROUNDINGS.

## SPECIFICATIONS

Detection speed range: ...	..0.3-3.0m/sec	Light immunity: ... ..not less than 10000 lux
Power input: ...	...8.5-16 VDC	Operating temperature range ... ..-30°C to +50°C
Current consumption: ...	...11.7 mA	Storage temperature range: ..... ..-40°C to +80°C
Pulse mode: ...	..bipolar, 1, 2,3,4	RFI immunity: .....30V/m
Alarm period: ...	... 3 sec	at a frequency range: ... ..10MHz-1000MHz
Detection range: ...	..18m	EMI immunity: .....>0.5kV
Relay output: ...	.. NC; 60V, 120mA, 16Ω	Weight: .....95gr.

# UBL-1110

## UNIVERSAL BRACKET.

**UBL-1110** - is a universal bracket for installing any type of PIR detectors, corner or wall mounted.

A distinguishing feature of the bracket is an inner duct for the wire, which allows to run the wire through the bracket and to connect the wires to the terminal block of PIR detector.

The construction of the bracket simplifies the installation of the devices and allows the precise angle adjustment.

## BRACKET FEATURES:

Different installation possibilities

Precise detector adjustment

Inner wire duct

Attractive design

High quality

Convenient Price

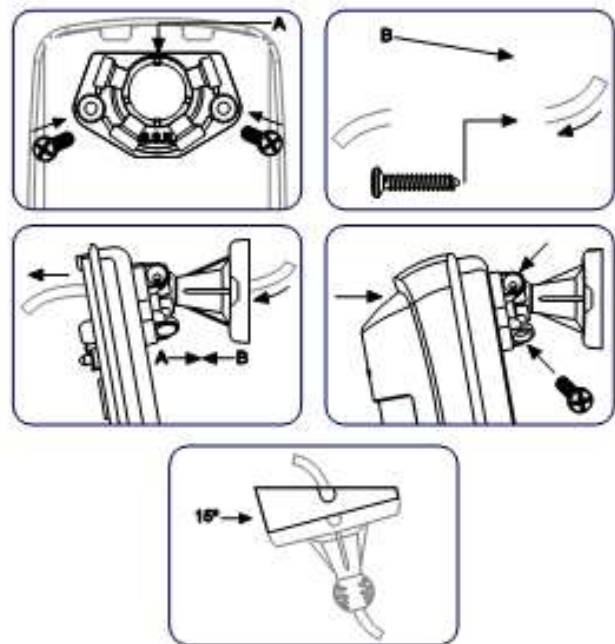

Inner wire duct

Component B is mounted to the wall with two screws.

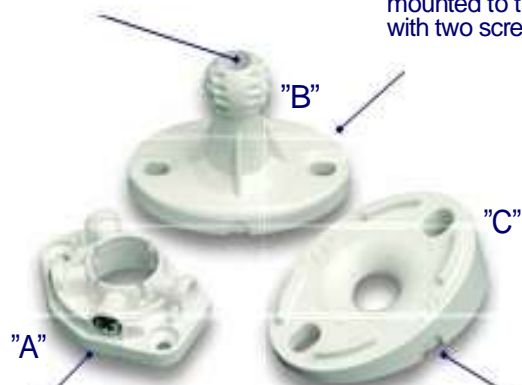

Component A is mounted to the back of the detector's housing with two screws.

An additional adaptor is used for the corner installation of the detector.

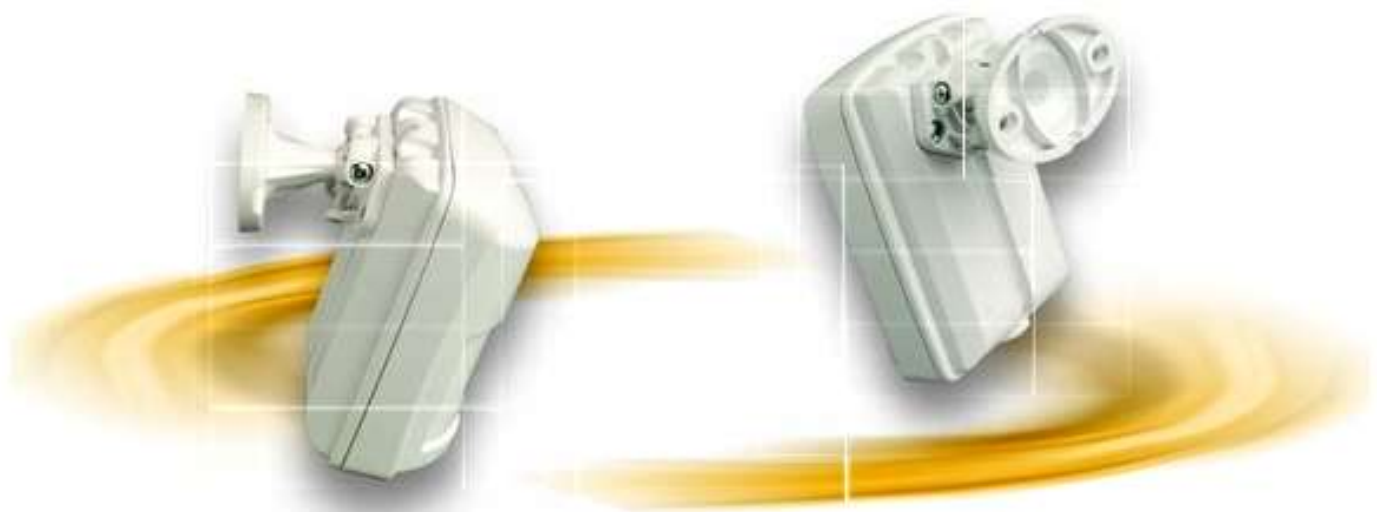



## LOOK DOWN ZONES

1. Move the PCB of the detector into position B.
2. Mount the **PATROL** detector onto the bracket at an angle of 10-15°.

In the current configuration lens diagram remains the same and the look down zone is enlarged.

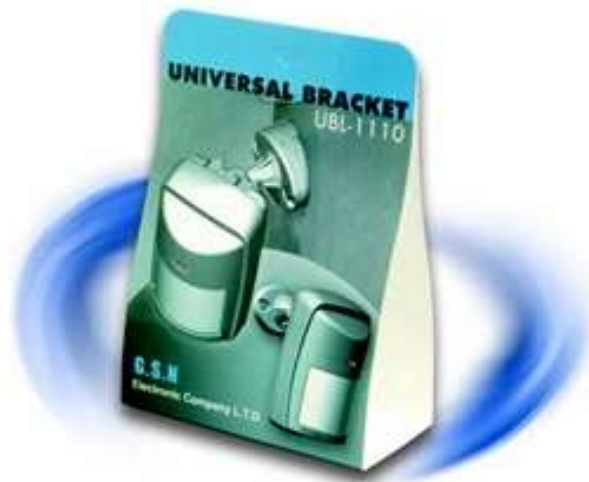
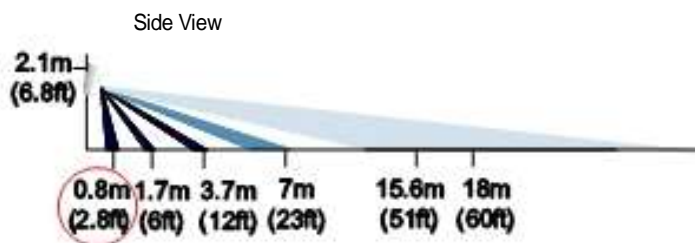
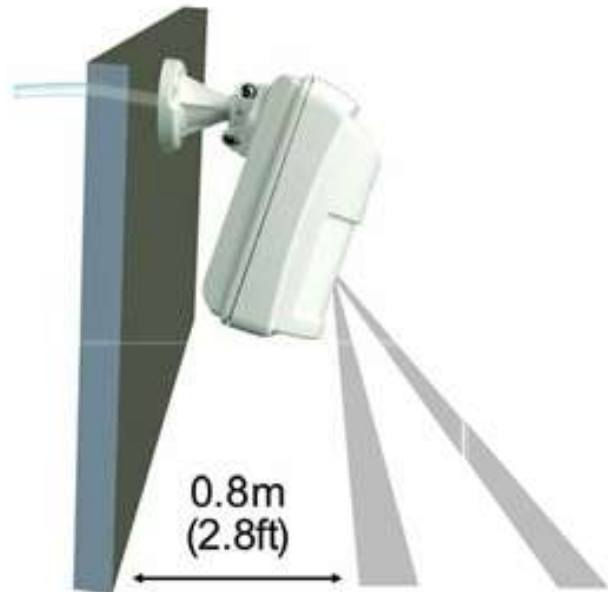
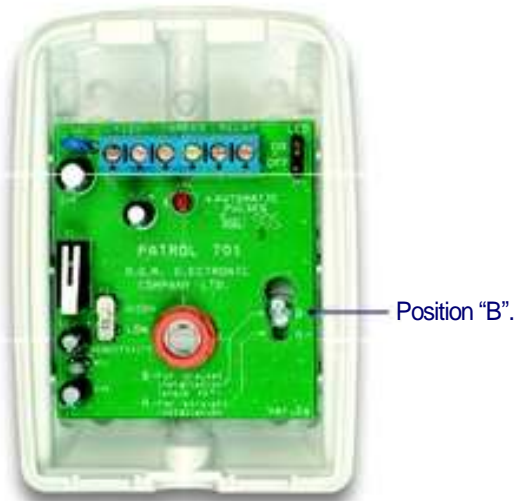

# WIRELESS PANIC BUTTONS

## ACS 101/102 WIRELESS ALARM SYSTEM SETS.

### PURPOSES

The wireless one-channel and dual-channel alarm system sets are multi purpose units, consisting of a receiver and hand-held panic button transmitters. It can be used in the following applications:

- Emergency warning by means of a panic button
- Arming/disarming of the alarm systems
- Remote controlling of electric gates, sliding doors, electric curtains, automatic barriers, electromagnetic locks - Turn on/off lights, etc.

### ADVANTAGES OF ACS 101/102

- 4 operating modes:
  - Panic Button Mode (SECURITY)
  - Switching Mode (ON/OFF)
  - Hold Mode (CONTINUOUS)
  - Pulse Mode 1 SECOND (PULSE)
- The receiver is capable of memorizing up to 680 codes and thus able to operate with 680 remote controls.
- Last event memory - 30 min.
- The alarm comes on when the electric power supply is disconnected (PANIC BUTTON MODE).
- Easy receiver programming by additional remote controls.
- SMT technology.



### ONE CHANNEL AND DUAL CHANNEL RECEIVERS ACS 101/102

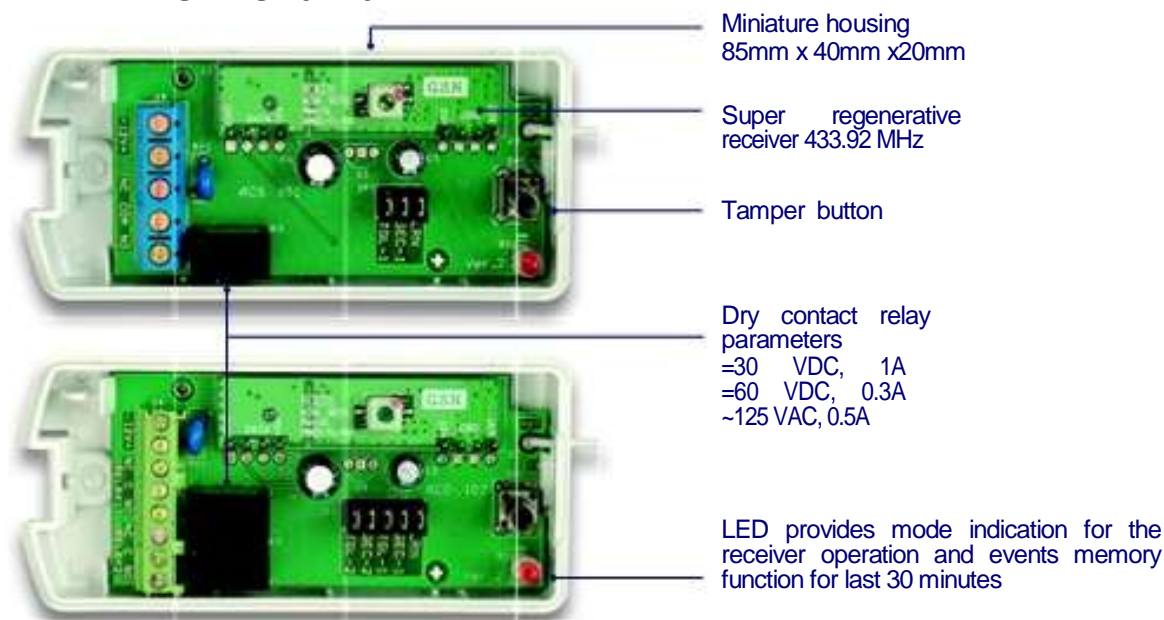

# WIRELESS PANIC BUTTONS

## REMOTE CONTROLS

Hand-held push-button transmitters are produced in dual-channel and four-channel standards. Each remote control has its own identity code to transmit a radio frequency signal to a remote receiver. The **ACS-101/102** receivers are capable of memorizing up to 680 different codes and therefore are able to operate with 680 remote controls, which have different identity codes.



## OPERATING RANGE

The operating range of the remote controls depends on the mounting location of the receivers. The various obstructions, the environmental factors, the radio frequency and electromagnetic sources might influence the emission of a radio-signal and as a result, might shorten the control range. For optimal radio-signal reception: mount the receiver at least 1 meter above the ground, as far as possible from any radio frequency and electromagnetic sources. The receiving range in open space is up to 200-250m.

## SPECIFICATIONS

Power input: ... ..	12-16VDC	Opening protection: .....	tamper switch
Current consumption:		Dry Contact Relay: ... ..	= 30 VDC, 1.0 A
ACS-101 .....	28mA - 12V		= 60 VDC, 0.3 A
ACS-102 .....	46mA - 12V		~125 VAC, 0.5 A
Receiving range in open space: .....	up to 200-250m	Operating temperature range ...	-20°C to +50°C
Operating frequency: ... ..	433.92 MHz	Storage temperature range: .....	-40°C to +80°C
Memory capacity: ... ..	680 codes	Dimensions: .....	85mm x 40mm x 20mm
Alarm period in security mode: ... ..	3 sec	Weight with two transmitters: ... ..	93 gr.
Warm up period: ... ..	0.5 sec		

# WIRELESS REMOTE CONTROL SETS

## ACS 112R, ACS 114R, ACS 124R, ACS 126R      PROFESSIONAL WIRELESS KEELOQ CODE HOPPING REMOTE CONTROL SETS.

### PURPOSE

The wireless one-channel and dual-channel receivers, operating in conjunction with hand-held push-button transmitters, provide the remote control of any electronic equipment:

- ELECTRICAL GATES
- SLIDING DOORS
- ELECTROMAGNETIC LOCKS
- AUTOMATIC BARRIERS
- ELECTRICAL CURTAINS
- LIGHTING FIXTURES, etc.

The remote control sets may be used as a PANIC BUTTON in security systems for creating any type of alarm.



### KEELOQ CODE PROTECTION

The multifunctional remote control sets use KEELOQ® code hopping technology, ensuring the highest level of security by code combination programmable but read-protected. The combinations of different codes transmitted by remote controls prevent radio scanning and unauthorized access.

### RECEIVING RANGE

Hand-held push-button remote controls are produced in two-channel and four-channel standards. The operating range of the hand-held remote controls depends on the mounting location of the receiver. The various obstructions, the environmental factors, the radio-frequency and electromagnetic sources might influence the emission of radio-signal and as a result, might shorten the receiving range. For optimal radio-signal reception: mount the receiver at least 1 meter above the ground, as far as possible from any radio frequency and electromagnetic sources. The receiving range in open space is up to 500m.



# WIRELESS REMOTE CONTROL SETS

## FEATURES

- FIVE OPERATING MODES:
  1. PULSE MODE - 1SECOND.
  2. SWITCH ON PERIOD MODE (1 - 300 sec).
  3. SWITCHING MODE (ON/OFF).
  4. HOLD MODE (CONTINUOUS).
  5. PANIC BUTTON MODE (SECURITY).



### ACS 112R - one-channel remote control receiver.

- Power input: 12-16VDC
- Receiving range in open space: up to 500m
- Memory capacity: 330 codes
- Security code: KEELOQ®

### ACS 114R - dual-channel remote control receiver.

- Power input: 12-16VDC
- Receiving range in open space: up to 500m
- Memory capacity: 330 codes
- Security code: KEELOQ®

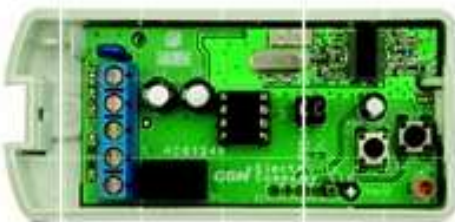

### ACS 124R - one-channel remote control receiver.

- Power input: AC/DC 24V  $\pm$  10%
- Receiving range in open space: up to 500m
- Memory capacity: 330 codes
- Security code: KEELOQ®
- Removable receiver memory device
- Unipolar supply voltage

### ACS 126R - dual-channel remote control receiver.

- Power input: AC/DC 24V  $\pm$  10%
- Receiving range in open space: up to 500m
- Memory capacity: 330 codes
- Security code: KEELOQ®
- Removable receiver memory device
- Unipolar supply voltage



## SPECIFICATIONS

Power input:  
 ACS-112R/114R: ..... 12-16 VDC  
 ACS-124R/126R: ..... AC/DC 24V  $\pm$  10%

Current consumption:  
 ACS-112R/114R: ..... 27mA/39mA  
 ACS-124R/126R: ..... 31mA/42mA

Receiving range in open space: ..... up to 500m

Operating frequency: ..... 433.92 MHz

Radiated power: .....  $\leq$ 10 mW

Security code: .....KEELOQ®

Memory capacity: ..... 330 codes

Dry contact relay: ...  
 .....DC30V/1.0A; DC60V/0.3A; AC125V/0.5A

Operating temperature range: ... -20°C to +50°C

Storage temperature range: ..... -40°C to +80°C

Dimensions: ..... 85mm x 40mm x 20mm

Weight: ..... 125 gr.

# WIRELESS REMOTE CONTROL SETS

## ACS 112/124PLUS, ACS 112R/124R PLUS WIRELESS MULTIFUNCTIONAL CONTROLLERS PROGRAMMED BY ADDITIONAL HAND HELD TRANSMITTERS FROM A DISTANCE.

### NEW SOLUTION

- Each transmitter can be programmed as a master transmitter.
- The controller uses a pre-programmed master transmitter to be programmed by additional hand-held transmitters from a distance.

### PURPOSE

The wireless one-channel controllers with hand-held pushbutton transmitters provide the remote control in multifunctional applications:

- Electrical Gates
- Electromagnetic Locks
- Sliding Doors
- Automatic Barriers
- Electrical Curtains
- Lighting Appliances, etc.

### ACS 112/124 PLUS, ACS 112R/124R PLUS'S FEATURES

- KEELOQ - Rolling Security Code for models **ACS-112R/124R PLUS**.
- The controller's memory device keeps all the pre-programmed codes, even after its removal from the PCB.
- The sound signal notifies incoming codes.
- High controller program protection from unauthorized access.  
Only the master transmitter's owner is permitted to program the controller by additional hand-held transmitters or program a new master transmitter.
- Power supply:  
for models **ACS-112/112R PLUS** - 12VAC/DC  
for models **ACS-124/124R PLUS** - 24VAC/DC



### OPERATING RANGE

The operating range of the hand-held transmitters depends on the mounting location of the controller.

The various obstructions, the environmental factors, the radio frequency and electromagnetic sources might influence the emission of radio-signal and as a result, might shorten the control range.

For optimal radio-signal reception: mount the controller at least 1 meter above the ground, as far as possible from radio frequency and electromagnetic sources.

The receiving range in open space - up to 200-250 meters.

# WIRELESS REMOTE CONTROL SETS

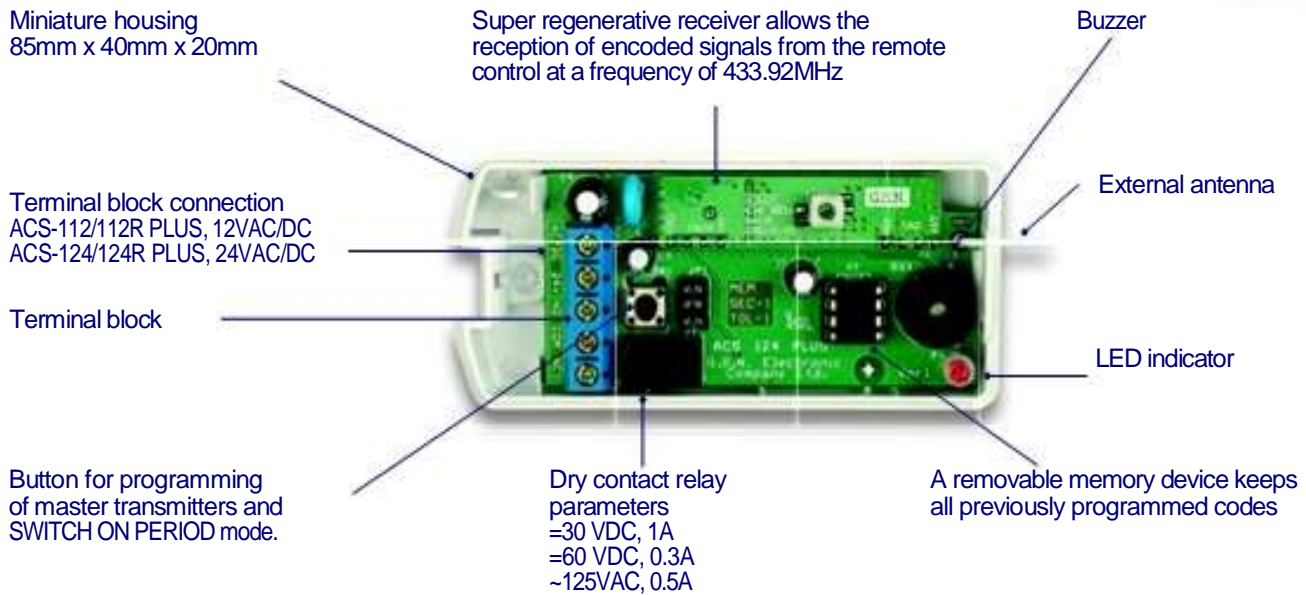

## OPERATING MODES OF ACS 112/124PLUS, ACS 112R/124R PLUS

- (SWITCH ON PERIOD) mode  
Programming the ON/OFF period for the desired time from 1 to 240 sec.
- Switching Mode (ON/OFF)
- Hold Mode (CONTINUOUS)
- Pulse Mode 1 SECOND (PULSE)

## SPECIFICATIONS

Power input:	Quantity of master transmitters: .....10
ACS-112/112R PLUS: .....12VAC/DC	Warm-up period: .....0.5 sec
ACS-124/124R PLUS: .....24VAC/DC	Dry contact relay: .....=30v, 1.0 A
Current consumption:	.....=60V, 0.3 A
ACS-112/112R PLUS: .....29mA 12V	.....~125V, 0.5 A
ACS-124/124R PLUS: .....33mA 24V	Operating temperature range: ... ..-20°C to +50°C
Receiving range in open space: ... ..200-250m	Storage temperature range: ..... -40°C to +80°C
Operating frequency: ... ..433.92MHz	Dimensions: ... ..85mm x 40mm x 20mm
Memory capacity:	Weight with two transmitters: ..... 97 gr.
ACS-112R/124R PLUS: ... ..330 codes	
ACS-112/124 PLUS: ... ..660 codes	

**GSN** *Electronic Company Ltd.*  
**www.gsncompany.com**

7 ATARA ST. NAZARETH ILLIT 17802 • P.O.Box 17719, ISRAEL  
TEL: +972 4 646 7152 • FAX: +972 4 656 2414  
<http://www.gsncompany.com> • Email: [gsn@gsncompany.com](mailto:gsn@gsncompany.com)